

**GAIN YOUR
SUPER
POWERS!**

ExpertSystem

Strict safety regulations, high total costs of ownership and the shortage of skilled professionals pose big challenges to door manufacturers and installers. This is why BBC Bircher Smart Access developed ExpertSystem. Being a comprehensive solution, ExpertSystem gives door manufacturers and installers superpowers and makes them heroes for gate safety.

Superpowers



- **High sensitivity** ensures fast activation behaviour
- **Optimal overtravel** allows for unrestricted and thus soft plasticity
- **Selectable safety level**
Cat. 2 / PLc or Cat. 3 / PLd

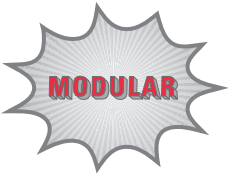

- **Large variety** of components
- **High flexibility** for various applications
- **Robust material** ideal for use in harsh and moist environments
- **Appealing look** blends harmoniously into gate design



- **Well thought out design** for faster than ever installation
- **Pluggable connectors** for fast wiring

System overview

Sensor edges

- High sensitivity
- Fast installation
- Appealing look

Plug connection system

- Watertight contact end piece
- Fast wiring
- Screwed for safe connection



Radio system

- Selectable safety level
- Radio range up to 100 m
- High interference immunity of signal

Quick mounting system

- Faster than ever mounting
- Easy edge exchange for maintenance
- Allows for pre-assembly in workshop

Sensor edges

Profiles

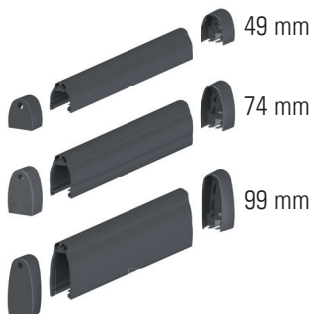

Aluminium rails

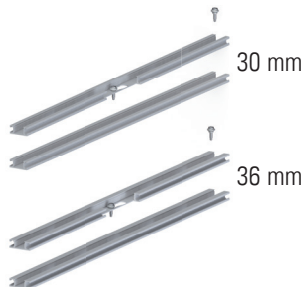

Radio system

Transmitter

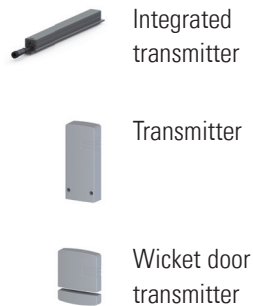

Receiver

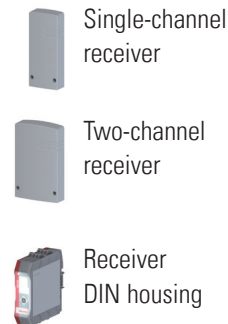

ProAccess



Vehicle detection sensor for barriers and gates

- Quick and easy to install thanks to above ground mounting
- With built-in heater and IP65 protection optimally suitable for outdoor operation
- Several features allow for convenient adaption to various applications



ProLoop2



Loop detector for industrial doors, gates, barriers and bollards

- Minimal start-up time thanks to simple programming and simulation capability
- Multitude of functions and flexible settings
- Automatic measurement and display of the loop inductivity

Service and logistics concept for ExpertSystem



Make-to-order system

- High quality through qualified process
- Quick-mounting system at gate / door
- Customer proximity through global production network
- Next day shipping



Kits

- In 2 metres standard length
- Low assembly effort
- Other lengths can be delivered on request



Self-assembly

- Compact packaging units
- Assembly in a few easy steps
- Quick-mounting system at gate / door
- High flexibility through modular system

BBC Bircher Smart Access

Wiesengasse 20

8222 Beringen

Switzerland

+41 52 687 11 11

info@bircher.com

www.bircher.com